



Electrolux
PROFESSIONAL

Premium Preparation 1600 mm Vegetables Processing Table with Upstand

ITEM # _____

MODEL # _____

NAME # _____

SIS # _____

AIA # _____



133069 (TLV1810PN)

Vegetables Processing/
Washing Table with 2 bowls,
1 polythene cutting board,
scraping hole and upstand,
1600mm

Short Form Specification

Item No. _____

50mm high worktop in 304 AISI stainless steel, 1,5mm in thickness, sound-deadened, anti-drip edges and welded corners. 2 bowls (684x303x180h mm). Integral radiused rear upstand, h=100mm with 10mm radius. All-round apron. Round section legs and feet in 304 AISI stainless steel, 50mm in diameter. N.1 polythene cutting board and scraping hole on front.

Main Features

- Sturdiness, stability and reliability of table accurately tested.

Construction

- 100 mm upstand with 10 mm radiused corner and 13 mm deep, designed to be used against a wall.
- Table can be equipped with a mobile bin with lid for waste disposal (optional accessory).
- Round section legs with feet in 304 AISI stainless steel, 50 mm in diameter, adjustable in height by +0/-40 mm.
- Table can be equipped with a set of castors as an alternative to the feet.
- Delivered in knock-down package.
- Single-pressed bowl AISI 304 stainless steel bowl with overflow pipe and drain hole.
- Wide range of taps are available to suit every need.
- Upstand back completely covered with Stainless Steel welded profile.
- Heavy duty construction entirely in AISI 304 stainless steel to offer maximum durability.

Optional Accessories

- Lower shelf for 1600mm for units PNC 855284
- Set of 4 wheels (2 with brake) d. 100mm PNC 855288
- 3-sided underframe for 1600mm tables PNC 855292
- Elbow operated mixer tap with spout 3/4", single hole PNC 855322
- Elbow operated mixer tap with short spout 3/4", single hole PNC 855323
- Foot operated mixer tap (hot and cold) with spout 3/4" PNC 855328

APPROVAL: _____



Experience the Excellence
www.electroluxprofessional.com

Front

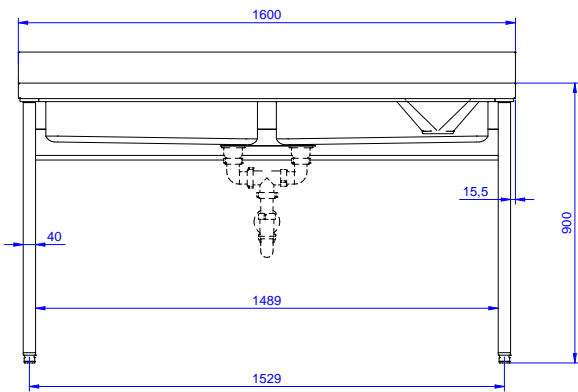

Side

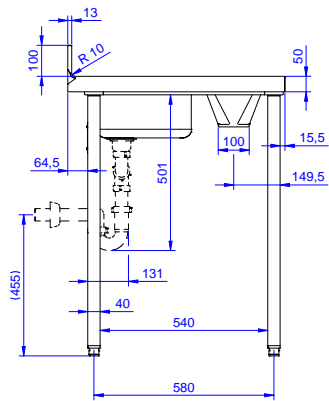

Top

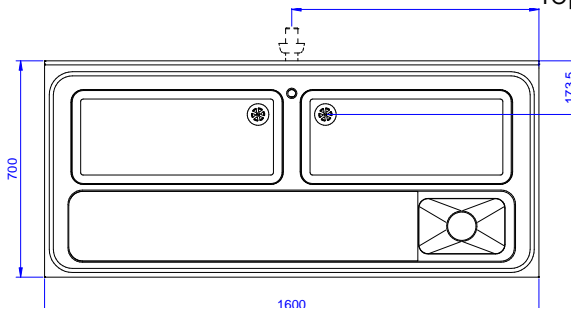



Electrolux
PROFESSIONAL

Premium Preparation 1600 mm Vegetables Processing Table with Upstand

Key Information:

External dimensions,
Width:

133069 (TLV1810PN) 1600 mm

External dimensions,
Depth:

700 mm

External dimensions,
Height:

1000 mm

Upstand Dimensions,
Height:

100 mm

Upstand Dimensions,
Depth:

13 mm

Upstand Dimensions,
Radius:

R=10

Worktop thickness:

50 mm

Net weight:

60 kg



Premium Preparation
1600 mm Vegetables Processing Table with Upstand

The company reserves the right to make modifications to the products
without prior notice. All information correct at time of printing.

2026.05.22